

We start where you aim

solar flame



Natural circulation solar water heaters
MAX series

Contents

MAX series solar water heaters	1
FMAX collectors	2
MAX tanks	4
MAX mounting brackets	5
Connection accessories.....	6
MAX configurations.....	7
STK high tilt series, 1 collector	7
STK high tilt series 2, collectors.....	8
STK high tilt series, 3 collectors.....	9
LPK series, 1 collector	10
LPK series, 2 collectors	11
LPK series, 3 collectors	12
ELITK series, low height, low tilt	13

MAX series solar water heaters

<ul style="list-style-type: none"> ✓ 49 certified models ✓ FMAX series collectors ✓ Max series storage tanks 	       						
Series benefits <ul style="list-style-type: none"> ➤ Very high yield all year ➤ One kit for flat or inclined surface ➤ 3 different configurations for all needs from 20° to 40° ➤ Extra low configuration with total height from 84 to 95cm ➤ High quality S320 steel supports with anticorrosion treatment on demand 	<table border="1" style="width: 100%; text-align: center;"> <tr> <th>Standard configuration</th> <th>Low profile configuration</th> <th>Extra low configuration</th> </tr> <tr> <td></td> <td></td> <td></td> </tr> </table>	Standard configuration	Low profile configuration	Extra low configuration			
Standard configuration	Low profile configuration	Extra low configuration					
							

Annual non solar heat demand, according to EU energy labeling and ecodesign requirements (CDR812/213)

Model	Source	Declared load profile	Energy label	Q _{nonsol} , Average [kWh]	Q _{nonsol} , Hot [kWh]	Q _{nonsol} , Cold [kWh]
160MAX200	NCSR Demokritos, SESL 097 SB 1	M	A	582	249	809
200MAX237	NCSR Demokritos, SESL 099 SB 1	M	A	529	196	763
300MAX400	NCSR Demokritos, SESL 100 SB 1	L	A	995	391	1424

Main dimensions of MAX series solar water heaters -selected kits-

Model	Storage	Collector/s	Standard support 40°				Low profile support 40°				Extra low profile 20°-28°			
			Max. Height [mm]	Max. Depth [mm]	Max. Width [mm]	Net Weight [kg]	Max. Height [mm]	Max. Depth [mm]	Max. Width [mm]	Net Weight [kg]	Max. Height [mm]	Max. Depth [mm]	Max. Width [mm]	Net Weight [kg]
120MAX150	MAX120	FMAX1.50	1635	1650	1150	105	1190	1765	1150	105	-	-	-	-
120MAX182	MAX120	FMAX1.82	1635	1650	1320	111	1190	1765	1320	111	-	-	-	-
160MAX182	MAX160	FMAX1.82	1635	1650	1320	120	1190	1765	1320	120	-	-	-	-
160MAX200	MAX160	FMAX2.00	1895	2080	1263	125	1490	2200	1263	126	950	2505	1263	120
160MAX200H	MAX160	FMAX2.00H	1435	1540	2100	120	1020	1660	2100	120	-	-	-	-
160MAX237	MAX160	FMAX2.37	1895	2080	1320	131	1490	2200	1320	132	950	2505	1320	125
160MAX237H	MAX160	FMAX2.37H	1435	1540	2050	127	1020	1660	2050	127	-	-	-	-
160MAX272	MAX160	FMAX2.72	2010	2240	1385	138	1630	2340	1385	147	950	2730	1385	140
160MAX272H	MAX160	FMAX2.72H	1435	1540	2280	133	1020	1660	2280	133	-	-	-	-
200MAX200	MAX200	FMAX2.00	1895	2080	1450	149	1490	2200	1450	150	950	2505	1450	143
200MAX200H	MAX200	FMAX2.00H	1435	1540	2100	142	1020	1660	2100	142	-	-	-	-
200MAX237	MAX200	FMAX2.37	1895	2080	1450	155	1490	2200	1450	156	950	2505	1450	150
200MAX237H	MAX200	FMAX2.37H	1435	1540	2050	150	1020	1660	2050	150	-	-	-	-
200MAX272	MAX200	FMAX2.72	2010	2240	1480	163	1630	2340	1480	164	950	2730	1480	158
200MAX272H	MAX200	FMAX2.72H	1435	1540	2280	157	1020	1660	2280	157	-	-	-	-
200MAX300	MAX200	2 x FMAX1.50	1635	1650	2180	165	1190	1765	2180	165	-	-	-	-
200MAX364	MAX200	2 x FMAX1.82	1635	1650	2600	176	1190	1765	2600	176	-	-	-	-
300MAX364	MAX300	2 x FMAX1.82	1635	1650	2600	216	1190	1765	2600	216	-	-	-	-
300MAX400	MAX300	2 x FMAX2.00	1895	2080	2180	226	1490	2200	2180	227	950	2505	2180	220
300MAX474	MAX300	2 x FMAX2.37	1895	2080	2600	238	1490	2200	2600	239	950	2505	2600	232
300MAX544	MAX300	2 x FMAX2.72	2010	2240	2715	252	1630	2340	2715	253	950	2730	2715	245
300MAX600	MAX300	3 x FMAX2.00	1895	2080	3315	283	1490	2200	3315	281	-	-	-	-
300MAX711	MAX300	3 x FMAX2.37	1895	2080	3975	301	1490	2200	3975	299	-	-	-	-
500MAX600*	MAX300	3 x FMAX2.00	-	-	-	-	1820	2390	3315	311	1350	2700	3315	301
500MAX711*	MAX300	3 x FMAX2.37	-	-	-	-	1820	2390	3975	328	1350	2700	3975	318
500MAX816*	MAX300	3 x FMAX2.72	-	-	-	-	1820	2490	4060	347	1350	2800	4060	337

FMAX collectors

- Harp type
- Ø8mm risers – closed loop
- Annual collector output:
2.72m² → 537 kWh/m² (Würzburg, 50°C)
Series: → 487 kWh/m² (Würzburg, 50°C)

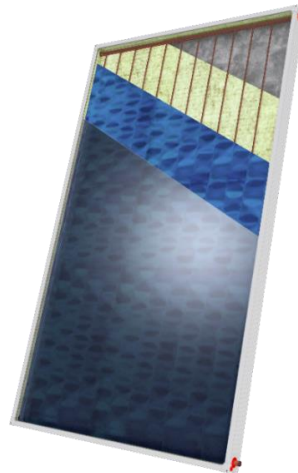
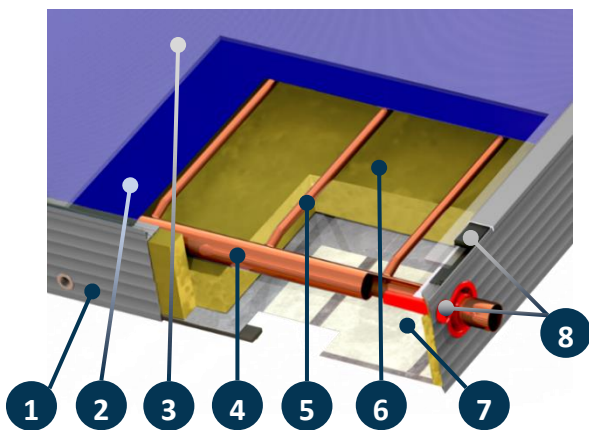
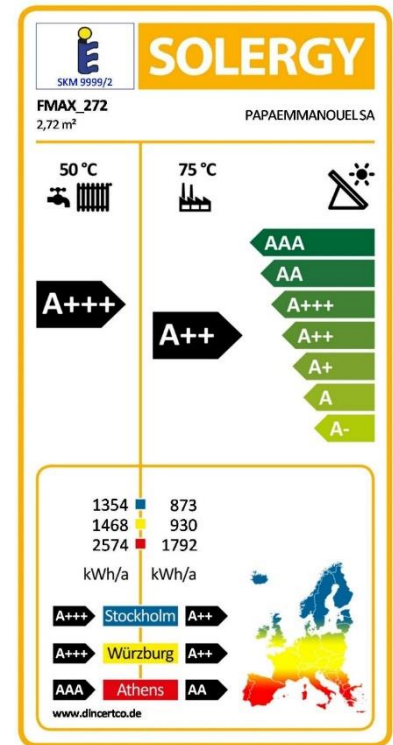

This series comprises of superior flat plate collectors encasing harp type absorber with very high efficiency level. It is best suited for closed loop /natural or forced circulation systems, small or large scale, great choice for mild and colder climates, where its great insulation properties are desired for minimizing thermal losses and maximizing efficiency.

Description:

1. **Frame of the collector:** Aluminium profile powder coated for maximum protection in seaside areas.
2. **Absorbing surface:** Aluminium surface with blue titanium high selective treatment with high absorption and low emission ($\alpha=95\%$, $\varepsilon=4\%$), laser welded on the copper water frame.
3. **Transparent cover:** Security-Tempered prismatic solar glass for maximum protection against extreme weather conditions and temperature changes.
4. **Header of water frame:** Copper tubes Ø22, which are welded to the vertical tubes with hard silver solder. Each water frame is tested at the pressure of 15 bars. Headers are punched with upper expansion for perfect fitting with vertical tubes and minimum pressure drop in the collector.
5. **Vertical tubes:** Copper tubes in diameter Ø8mm.
6. **Thermal insulation:** 40mm thick layer of prepressed mineral wool special for solar panels for minimum thermal loss. Thermal conductivity: $0=0.035$ W/m²K (EN 13162) and heat capacity 0.84 kJ/kgK.
7. **Back cover:** Aluzinc 0,4mm thick. Aluzinc stands for aluminium and zinc, fused in almost equal proportions, as a coating for the steel sheet that is coated with a silvery spangle composed of Aluminium (55%), Zinc (43,4%) and a touch of Silicon (1,6%). Great mechanical strength and 7 times more resistant to corrosion than common galvanized steel.
8. **Sealing materials:** For perfect waterproof finish and proper ventilation of collectors casing, all materials used (EPDM, polyurethane sealant, silicon air vents and silicon header flanges) resist to extreme weather conditions and temperature changes.

The collector can be installed on a flat roof or tiled roof.

COLLECTORS TECHNICAL DATA / SPECIFICATIONS

Model	1.50 V	1.50 H	1.82 V	1.82 H	2.00 V	2.00 H	2.37 V	2.37 H	2.72 V	2.72 H
Gross area [m ²]	1.50	1.50	1.82	1.82	2.00	2.00	2.37	2.37	2.72	2.72
Total Dimensions [mm]	L:1480	L:1010	L:1480	L:1230	L:1980	L:1010	L:1930	L:1230	L:2160	L:1260
	W:1010	HW:1480	HW:1230	HW:1480	HW:1010	HW:1980	HW:1230	HW:1930	HW:1260	HW:2160
Weight empty [kg]	:86	:86	:86	:86	:86	:86	:86	:86	:86	:86
Max. operating Pressure [bar]	10									
Thermal Liquid Capacity [lt]	1.22	1.56	1.48	1.68	1.41	2.04	1.69	2.17	1.81	2.30
Collector front Cover-Thickness	LOW IRON TEMPERED GLASS 3.2mm									
Insulation	40mm-50kg/m ³ MINERAL WOOL, λ=0.035 [W/(mK)]									
Casing Material	ALUMINUM POWDER COATED									
Sealing Materials	POLYURETHANE - SILICON - EPDM									
Absorber Area [m ²]	1.38	1.38	1.72	1.72	1.86	1.86	2.23	2.23	2.57	2.57
Water-frame type/material/diameter	Harp type, copper, ø22 headers-ø8 risers									
Nr. Of risers	9	14	11	14	9	18	11	18	11	18
Absorber Material-Treatment	ALUMINUM / PVD COATING / HIGH SELECTIVE – A=0.95±0.02 / e=0.05±0.02									
Absorber construction Type	LASER									
Heat transfer Medium	POLYPROPYLENE OR TRIETHYLENE GLYCOL + WATER MIXTURE									
Tests and Certifications	SOLAR KEYMARK									
EFFICIENCY VALUES BASED ON EN ISO 9806:2013 STANDARD (BASED ON GROSS AREA)										
SKM9999.1										
SKM9999.2										
Efficiency η _{0,b}	For the family: 0.771					For 2.72: 0.784				
Thermal loss a ₁ [w/(m ² K)]	For the family: 3.59					For 2.72: 3.15				
IAM (Kθ at 50°)	0.96					0.96				
Thermal loss a ₂ [w/(m ² K ²)	For the family: 0.014					For 2.72: 0.012				
Stagnation temp. [°C]	190.5					190.5				
η _{col}	For the family: 60%					For 2.72: 63%				

LAYOUT

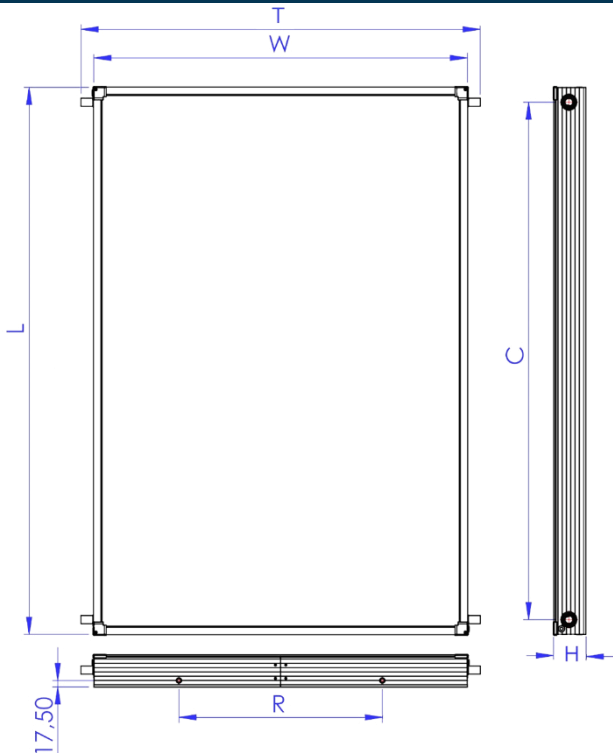

CRITICAL DIMENSIONS

model	L	W	H	C	T	R
1.50V	1480	1010	86	1400	1080	550
1.50H	1010	1480	86	930	1560	1000
1.82V	1480	1230	86	1400	1300	550
1.82H	1230	1480	86	1150	1560	1000
2.00V	1980	1010	86	1900	1080	550
2.00H	1010	1980	86	930	2050	1000
2.37V	1930	1230	86	1850	1300	550
2.37H	1230	1930	86	1150	2010	1000
2.72V	2160	1260	86	2080	1340	550
2.72H	1260	2160	86	1180	2240	1000

*R: M8 blind rivets position and spacing for mounting on a support structure. Located on both top and bottom side of the collector (2+2 rivets)

MAX tanks

- Double layer of enamel
 - Tank with 3mm thickness
 - High density Insulation (50kg/m³)
- 

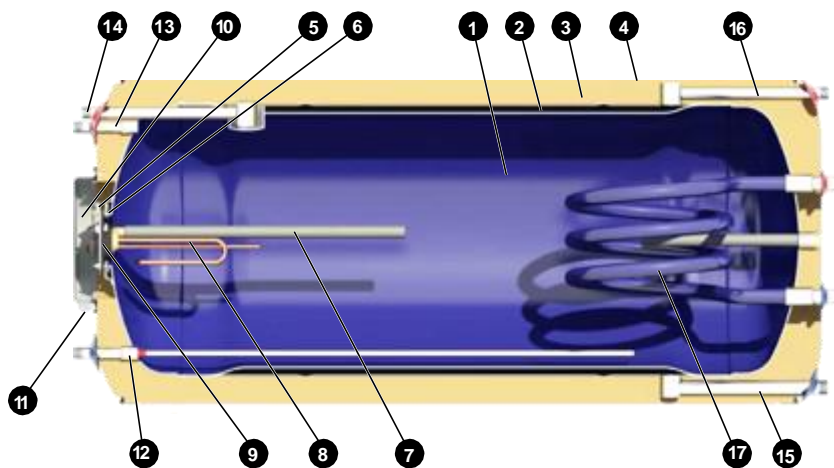

1. **Water storage tank:** Consists of cold rolled steel, 3mm thick with double internal layer of enamel, processed at 860° c, according to DIN 4753 Standard.
2. **Double jacket heat exchanger:** Consisting of cold rolled steel, 1.5mm thick, for the function of the closed loop circuit. The jacket is properly formed for resistance to contractions and expansions, during the operation of the solar system.
3. **Thermal insulation:** Ecological, incombustible and high-density (>50kg/m³) expanded polyurethane surrounds the water storage tank and jacket for minimum heat loss, maintaining the hot water temperature, thickness 50mm.
4. **External casing:** Hot dip galvanized steel, powder coated RAL9006 / marine grade aluminum alloy.
5. **Side flange:** Wide opening for easy cleaning of minerals, inspection of the tank and maintenance.
6. **Flange sealing:** The flange is sealed with a silicon sealant with high heat resistance.
7. **Cathode protection:** 2 Magnesium anode rods for protection against corrosion and mineral deposits caused by electrolytic reactions.
8. **Heating element:** Rated according to the destination country's local regulations (optional, for the use of electricity as an auxiliary power source).
9. **Safety thermostat (optional standard only in case that electric heating element is present):** With bipolar protection and auxiliary fuse. All electrical components carry a CE marking according to EN 60335-1 and EN 660335-2-21 standards.
10. **Protective cover:** Protection of the electrical part.
11. **Cable gland and cable tube:** Water resistant passage for the electric element's electric connections.
12. **Cold Water inlet:** Inox BSP male threaded pipe end (3/4" for 250, 300 & 500lt tank and 1/2" for rest). At this connection a 9 bar safety non return valve must be placed for pressure relief.
13. **Hot Water (DHW) outlet:** Inox BSP male threaded pipe end (3/4" for 250, 300 & 500lt tank and 1/2" for rest).
14. **Jacket inlet:** 3/4" BSP male threaded pipe end. A tee fitting is attached which also provides the filling point for the closed circuit, which must be plugged after filling is done.
15. **Jacket outlet:** 3/4" BSP male threaded pipe end.
16. **2.5 bar safety valve connection point:** Inox 1/2" BSP male threaded pipe end.
17. **Heat exchanger coil:** Optional part, with 3/4" BSP male threaded ends for use with conventional heating systems.

BOMAX SERIES BOILERS TECHNICAL DATA / SPECIFICATIONS							
Model		120	160	200	250	300	500
Capacity	[lt]	117	156	197	249	286	468
Dimensions DxL	[mm]	580x927	580x1151	580x1369	580x1769	580x1977	700x2120
Protection - treatment – of main tank		ENAMELED + MG ANODE ROD					
Insulation material - density	[kg/m ³]	ENVIROMENTALLY FRIENDLY EXPANDED POLYURETHANE (50 kg/m ³)					
Maximum operating Temperature	[°C]	99					
Maximum working Pressure	[bars]	10	10	10	10	10	10
Maximum closed loop Pressure	[bars]	2.5	2.5	2.5	2.5	2.5	1.5
Heat exchanger capacity (jacket)	[lt]	5.4	8.8	13.1	18.9	18.9	34
Heat exchanger surface (jacket)	[m ²]	0.6	0.9	1.3	1.8	1.8	2.1
Weight empty	[kg]	59	68	92	112	132	149

MAX mounting brackets

STK support system

Standard configuration, flat /inclined roof installation, low or high tilt



LPK support system

Low profile configuration, flat /inclined roof installation, high tilt

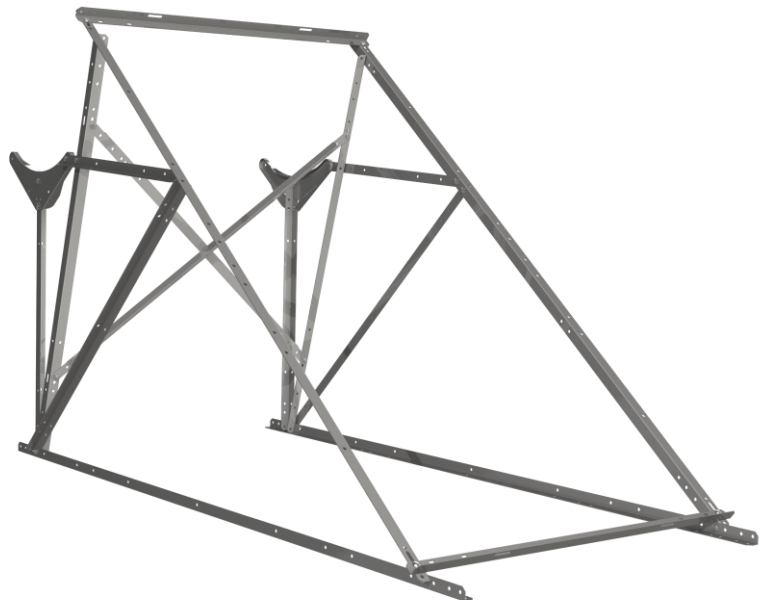

ELITK support system

Very low profile (maximum height of solar kit is 950mm), flat roof installation, low tilt



- ✓ The mounting brackets are made out of high-grade steel (S320).
- ✓ They are standard galvanized and may be even treated with highly anti-corrosive layer e.g. Magnelis.

Connection accessories

DESCRIPTION	SAMPLE IMAGES	1 x collector	2 x collectors	3 x collectors
1 PLUG FOR COPPER TUBE Ø22 MECHANICAL TIGHTENING		2	2	2
2 ELBOW FITTING FOR COPPER TUBE Ø22 MECHANICAL TIGHTENING X INOX DN16 TUBE		2	2	2
3 ELBOW FITTING FOR 3/4" FEMALE X INOX DN16 TUBE		1	1	0
4 STRAIGHT FITTING FOR 3/4" FEMALE X INOX DN16 TUBE		0	0	2
5 TEE FITTING INOX DN16 TUBE x 3/4" FEMALE x 3/4" FEMALE		1	1	1
6 ELBOW FITTING MALE 1/2" x 1/2" FEMALE		1	1	1
7 STRAIGHT FITTING FOR Ø22mm COPPER TUBE		0	2	4
8 MALE PLUG 3/4"		1	1	1
9 SAFETY VALVE 2 BAR 1/2" FEMALE FOR CLOSE LOOP CIRCUIT		1	1	1
10 SAFETY NON RETURN VALVE 9 BAR FOR INLET OF CITY COLD WATER		1/2"	1/2" → 200lt 3/4" → 250-300lt	-
11 BALL VALVE FOR INLET OF CITY COLD WATER (OPTIONAL)		1/2"	1/2" → 200lt 3/4" → 250-300lt	-
12 EXPANSION VESSEL 1lt FOR CLOSE CIRCUIT (OPTIONAL PART)		1	1	1
13 ANTIFREEZE LIQUID* <i>*Demanded Antifreeze quantity may differ</i>		1lt → 120lt 2lt → 160-200lt	2lt → 200lt 3lt → 250-300lt	4lt
14 THERMOSTATIC MIXING VALVE (OPTIONAL PART)		1	1	1
15 TEMPERATURE AND PRESSURE RELIEF VALVE 10BAR / 95°C (OPTIONAL PART)		1	1	1
16 STAINLESS STEEL CORRUGATED TUBES INSULATED WITH UV PROTECTED INSULATION		2	2	2
17 TEE FITTING F (OPTIONAL PART WHEN T&P VALVE IS USED)		1/2"	1/2" → 200lt 3/4" → 250-300lt	3/4"
18 REDUCER 3/4" M X 1/2" / F (OPTIONAL PART WHEN NEEDED)		1	1	1
20 SAFETY GROUP 3/4" (ALTERNATIVE FOR N.10 & 11)		1	1	1

MAX configurations

STK high tilt series, 1 collector

SYSTEMS WITH ONE COLLECTOR, SAME SUPPORT FOR FLAT OR INCLINED CONFIGURATION

flat roof configuration

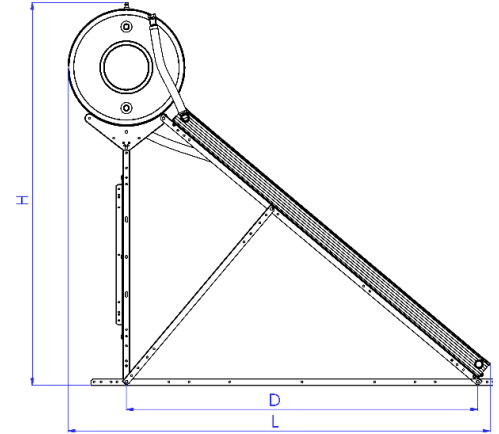
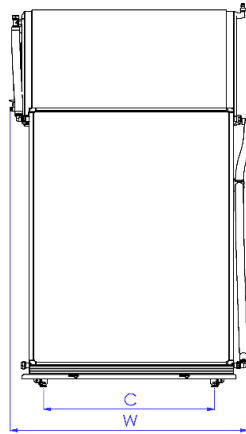

Inclined roof configuration

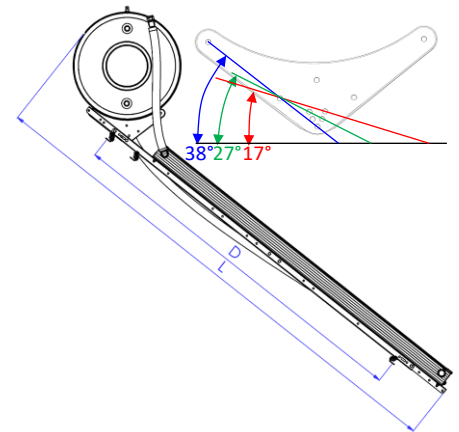
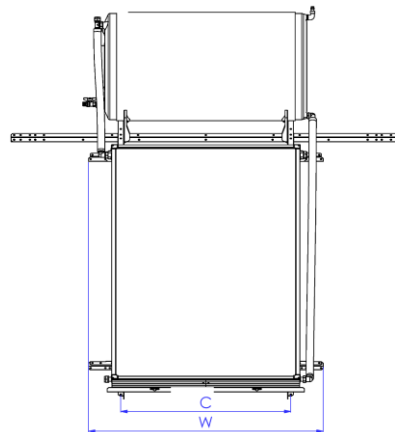
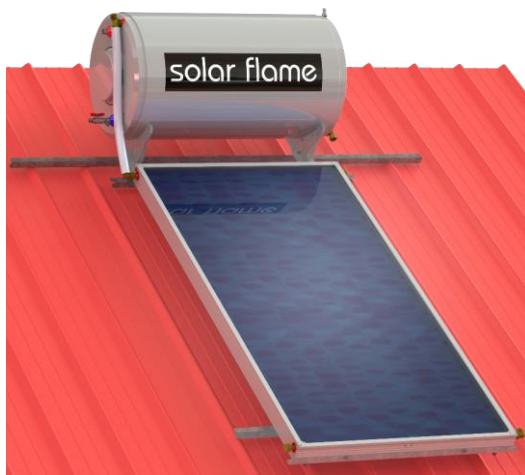

SYSTEM MAIN DIMENSIONS

Model	C [mm] flat	C [mm] inclined	W [mm] flat	W [mm] inclined	H [mm] flat	L [mm] flat	L [mm] inclined	D [mm] flat	D [mm] inclined	Weight empty [kg]
120lt-1x1.50m ²	655	725	1150	1150	1635	1650	2230	1300	1545	105
120lt-1x1.82m ²	655	725	1320	1320	1635	1650	2230	1300	1545	111
120lt-1x2.00m ²	655	725	1150	1263	1895	2080	2930	1740	2110	119
160lt-1x1.82m ²	845	915	1320	1320	1635	1650	2230	1300	1545	120
160lt-1x2.00m ²	845	915	1250	1263	1895	2080	2715	1740	2110	126
160lt-1x2.37m ²	845	915	1320	1320	1895	2080	2715	1740	2110	132
160lt-1x2.72m ²	845	915	1385	1385	2010	2240	2930	1892	2150	147
200lt-1x2.00 m ²	935	1005	1450	1450	1895	2080	2715	1740	2110	150
200lt-1x2.37 m ²	935	1005	1450	1450	1895	2080	2715	1740	2110	156
200lt-1x2.72m ²	935	1005	1480	1480	2010	2240	2930	1892	2150	164
250lt-1x2.72m ²	935	1005	1840	1840	2010	2240	2930	1892	2150	189

STK high tilt series 2, collectors

SYSTEMS WITH TWO COLLECTORS, SAME SUPPORT FOR FLAT OR INCLINED CONFIGURATION

flat roof configuration

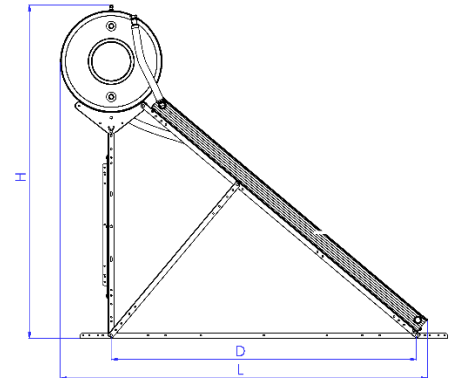
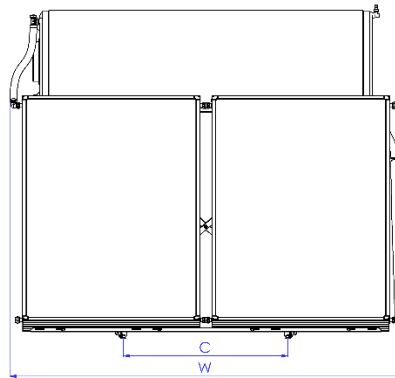

Inclined roof configuration

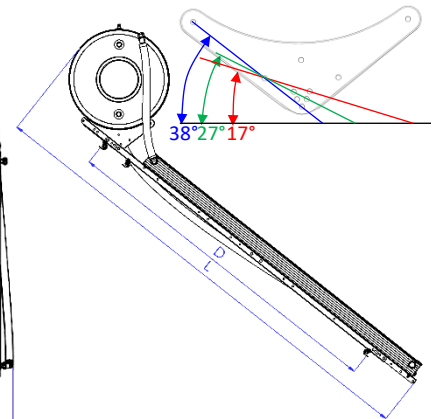
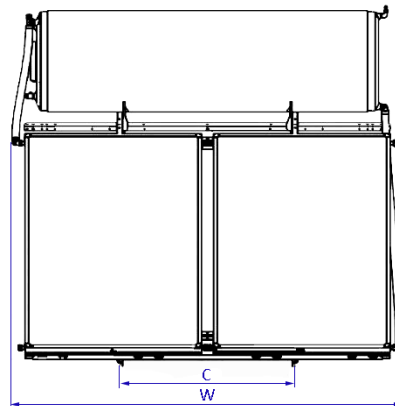
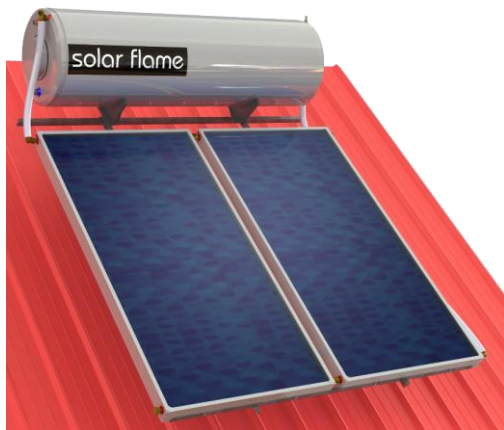

SYSTEM MAIN DIMENSIONS

Model	C [mm] flat	C [mm] inclined	W [mm] flat	W [mm] inclined	H [mm] flat	L [mm] flat	L [mm] inclined	D [mm] flat	D [mm] inclined	Weight empty [kg]
160lt-2x1.50m ²	845	915	2180	2180	1635	1650	2230	1300	1545	149
200lt-2x1.50m ²	935	1005	2180	2180	1635	1650	2230	1300	1545	165
200lt-2x1.82m ²	935	1005	2600	2600	1635	1650	2230	1300	1545	176
200lt-2x2.00 m ²	935	1005	2180	2180	1895	2080	2715	1740	2110	188
250lt-2x1.50m ²	935	1005	2180	2180	1635	1650	2230	1300	1545	192
250lt-2x1.82m ²	935	1005	2600	2600	1635	1650	2230	1300	1545	203
250lt-2x2.00 m ²	935	1005	2180	2180	1895	2080	2715	1740	2110	213
250lt-2x2.37 m ²	935	1005	2600	2600	1895	2080	2715	1740	2110	239
250lt-2x2.72m ²	935	1005	2715	2715	2010	2240	2930	1892	2150	238
300lt-2x1.50m ²	935	1005	2180	2180	1635	1650	2230	1300	1545	205
300lt-2x1.82m ²	935	1005	2600	2600	1635	1650	2230	1300	1545	216
300lt-2x2.00 m ²	935	1005	2180	2180	1895	2080	2715	1740	2110	226
300lt-2x2.37 m ²	935	1005	2600	2600	1895	2080	2715	1740	2110	238
300lt-2x2.72m ²	935	1005	2715	2715	2010	2240	2930	1892	2150	252

STK high tilt series, 3 collectors

SYSTEMS WITH THREE COLLECTORS, SAME SUPPORT FOR FLAT OR INCLINED CONFIGURATION

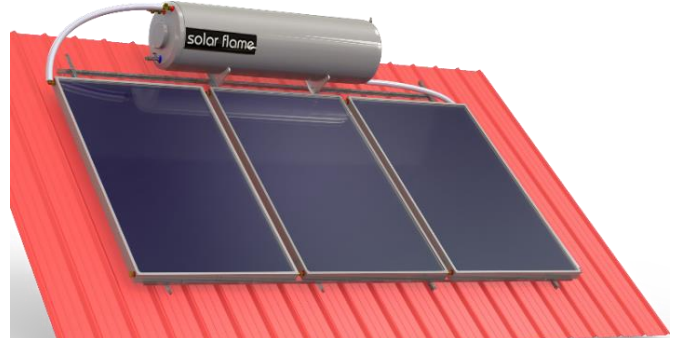

Flat roof main dimensions

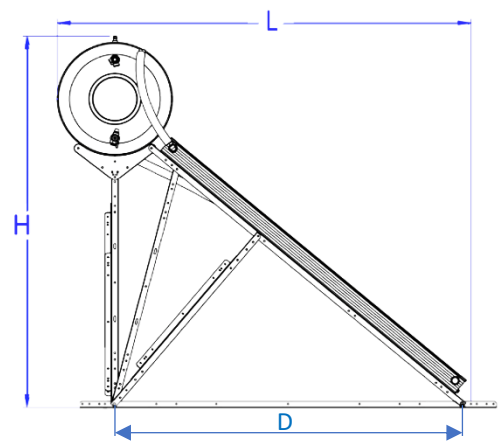
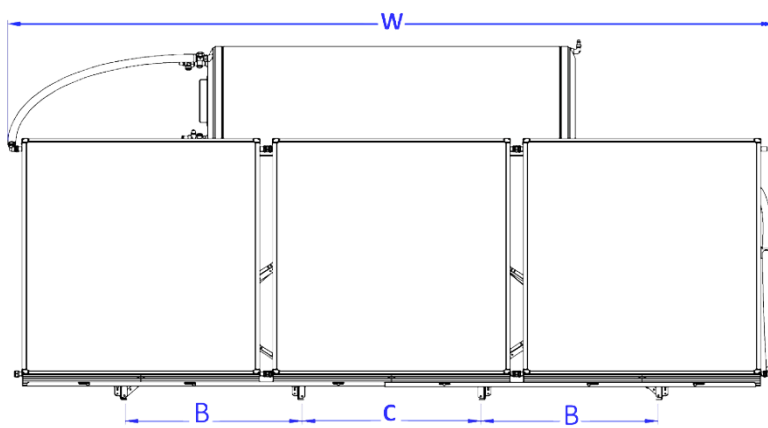

Inclined roof main dimensions

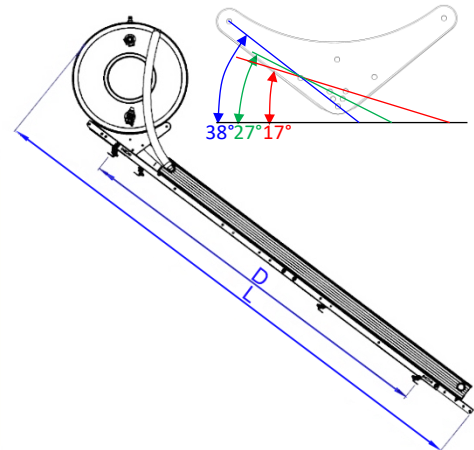
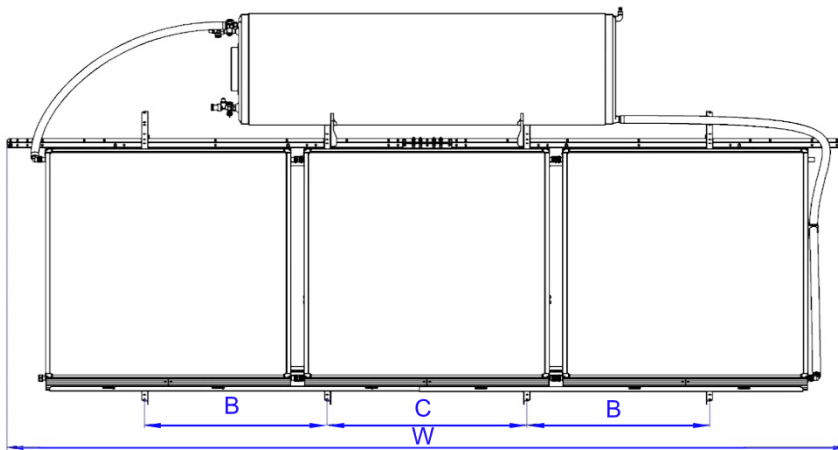

SYSTEM MAIN DIMENSIONS

Model	Model	C [mm]	B [mm]	W [mm]	H [mm]	L [mm]	D [mm]	Weight empty [kg]
Flat roof	300lt-3x2.00m ²	935	920	3315	1895	2080	1740	283
	300lt-3x2.37m ²	935	920	3975	1895	2080	1740	301
	300lt-3x2.72m ²	935	920	4065	2010	2240	1892	319
Inclined roof	300lt-3x2.00m ²	1005	920	3315	-	2930	2110	283
	300lt-3x2.37m ²	1005	920	3975	-	2930	2110	301
	300lt-3x2.72m ²	1005	920	4065	-	2930	2150	319

LPK series, 1 collector

SYSTEMS WITH ONE COLLECTOR, SAME SUPPORT FOR FLAT OR INCLINED CONFIGURATION

flat roof configuration

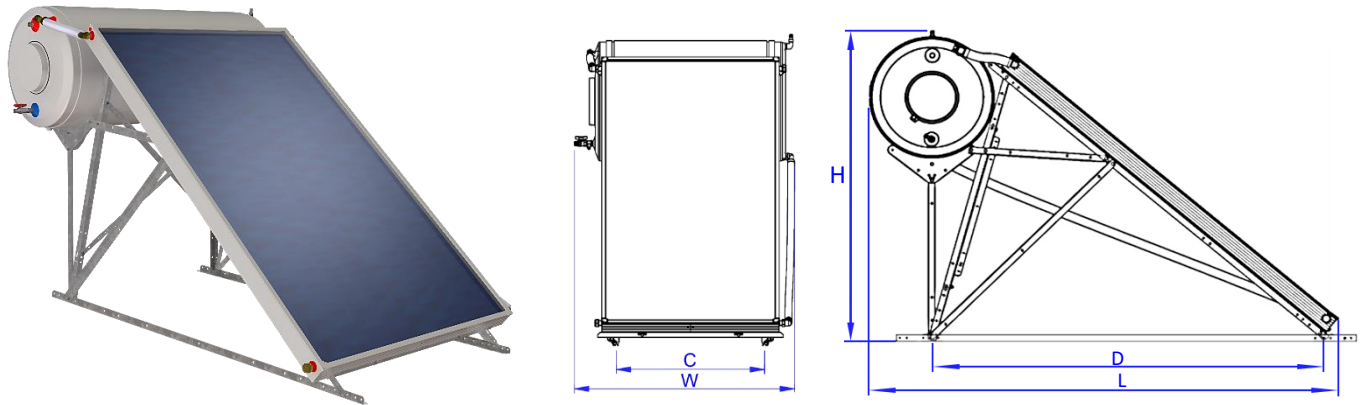

Inclined roof configuration

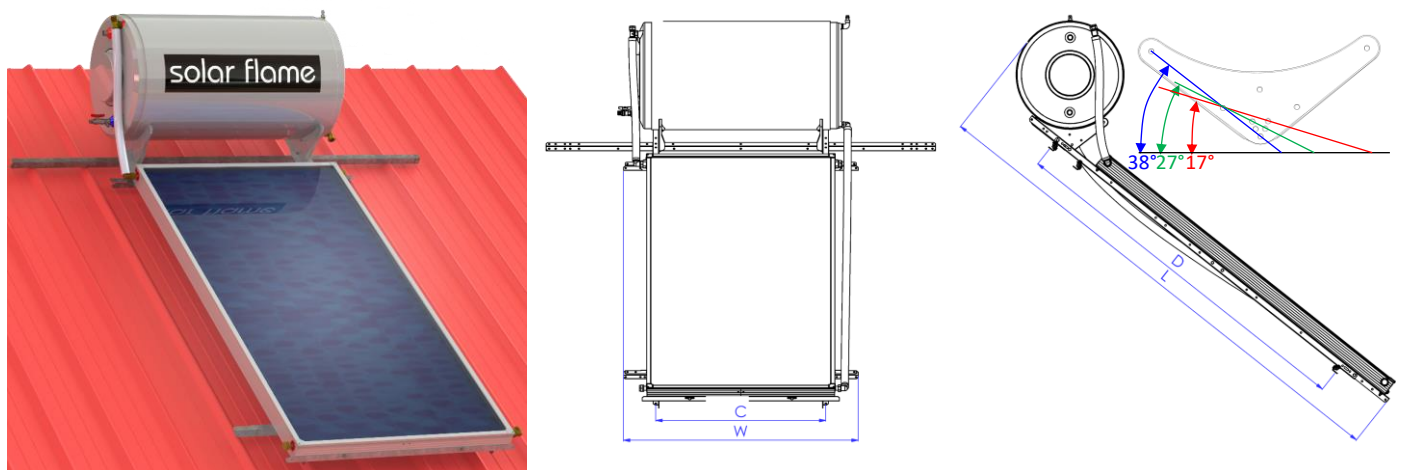

SYSTEM MAIN DIMENSIONS

Model	C [mm] flat	C [mm] inclined	W [mm] flat	W [mm] inclined	H [mm] flat	L [mm] flat	L [mm] inclined	D [mm] flat	D [mm] inclined	Weight empty [kg]
160lt-1x2.00m ²	845	915	1250	1263	1490	2200	2540	1835	1940	126
160lt-1x2.37m ²	845	915	1320	1320	1490	2200	2540	1835	1940	132
160lt-1x2.72m ²	845	915	1385	1385	1630	2340	2930	1992	2166	139
200lt-1x2.00 m ²	935	1005	1450	1450	1490	2200	2540	1835	1940	150
200lt-1x2.37 m ²	935	1005	1450	1450	1490	2200	2540	1835	1940	156
200lt-1x2.72m ²	935	1005	1480	1480	1630	2340	2930	1992	2166	164
250lt-1x2.72m ²	935	1005	1840	1840	1630	2340	2930	1992	2166	190

LPK series, 2 collectors

SYSTEMS WITH TWO COLLECTORS, SAME SUPPORT FOR FLAT OR INCLINED CONFIGURATION

flat roof configuration

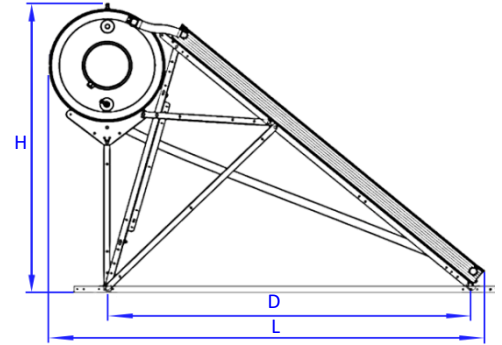
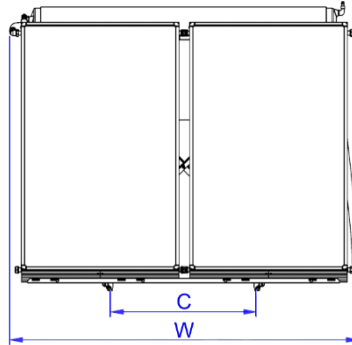

Inclined roof configuration

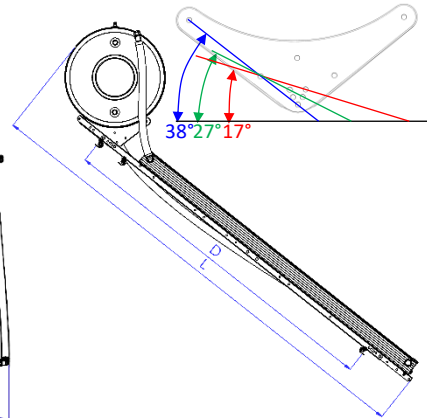
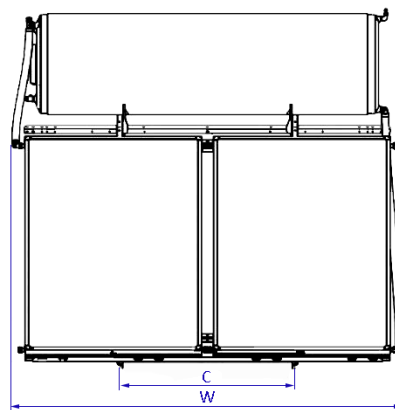
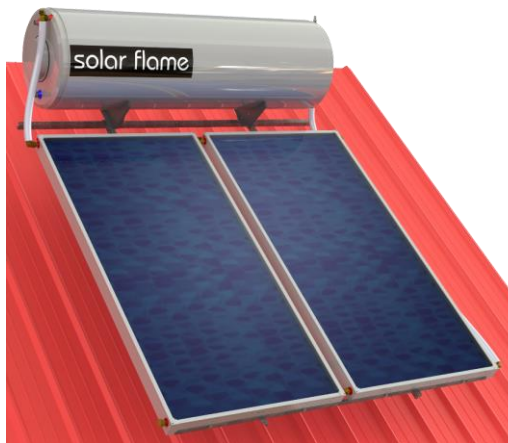

SYSTEM MAIN DIMENSIONS

Model	C [mm] flat	C [mm] inclined	W [mm] flat	W [mm] inclined	H [mm] flat	L [mm] flat	L [mm] inclined	D [mm] flat	D [mm] inclined	Weight empty [kg]
160lt-2x1.50m ²	845	915	2180	2180	1240	1750	2200	1433	1400	150
200lt-2x1.50m ²	935	1005	2180	2180	1240	1750	2200	1433	1400	165
200lt-2x1.82m ²	935	1005	2600	2600	1240	1750	2200	1433	1400	176
200lt-2x2.00 m ²	935	1005	2180	2180	1490	2200	2540	1835	1940	189
250lt-2x1.50m ²	935	1005	2180	2180	1240	1750	2200	1433	1400	193
250lt-2x1.82m ²	935	1005	2600	2600	1240	1750	2200	1433	1400	204
250lt-2x2.00 m ²	935	1005	2180	2180	1490	2200	2540	1835	1940	214
250lt-2x2.37 m ²	935	1005	2600	2600	1490	2200	2540	1835	1940	226
250lt-2x2.72m ²	935	1005	2715	2715	1630	2340	2930	1992	2166	239
300lt-2x1.50m ²	935	1005	2180	2180	1240	1750	2200	1433	1400	206
300lt-2x1.82m ²	935	1005	2600	2600	1240	1750	2200	1433	1400	216
300lt-2x2.00 m ²	935	1005	2180	2180	1490	2200	2540	1835	1940	227
300lt-2x2.37 m ²	935	1005	2600	2600	1490	2200	2540	1835	1940	239
300lt-2x2.72m ²	935	1005	2715	2715	1630	2340	2930	1992	2166	253

LPK series, 3 collectors

SYSTEMS WITH THREE COLLECTORS, SAME SUPPORT FOR FLAT OR INCLINED CONFIGURATION

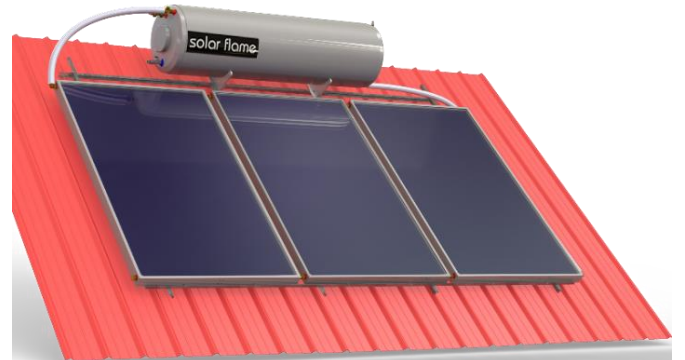
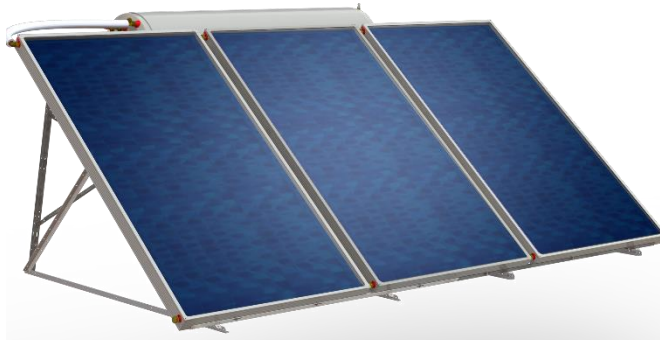

Flat roof main dimensions

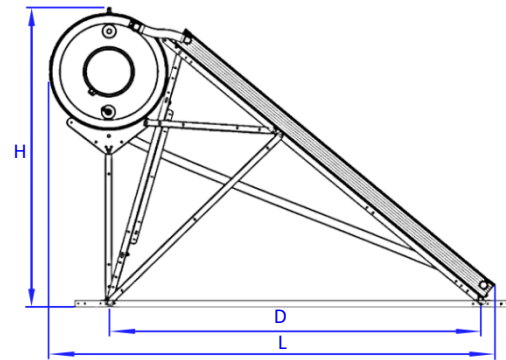
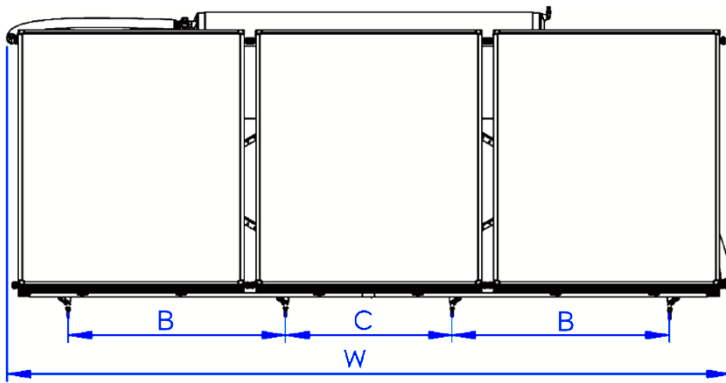

Inclined roof main dimensions

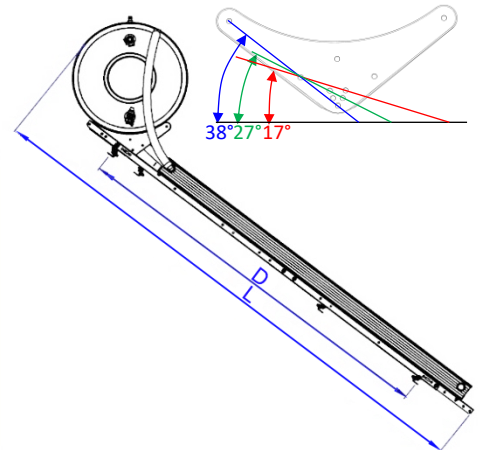
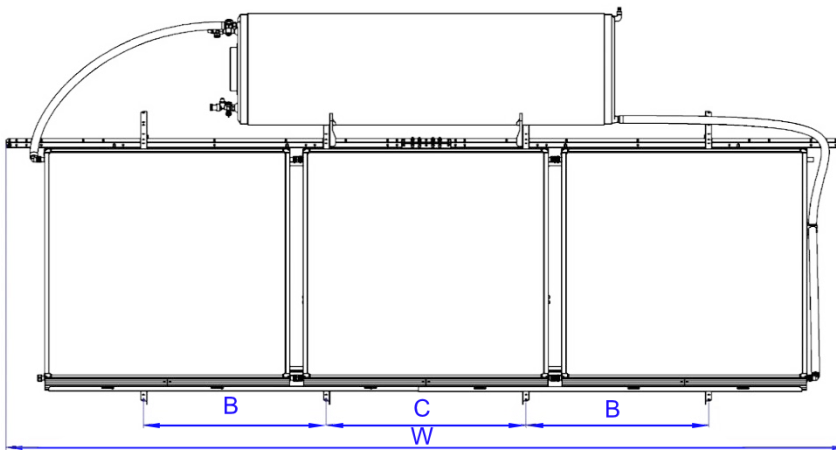

SYSTEM MAIN DIMENSIONS

Model	Model	C [mm]	B [mm]	W [mm]	H [mm]	L [mm]	D [mm]	Weight empty [kg]
Flat roof	300lt-3x2.00m ²	935	920	3315	1490	2200	1835	281
	300lt-3x2.37m ²	935	920	3975	1490	2200	1835	299
	300lt-3x2.72m ²	935	1220	4065	1630	2340	1992	317
Inclined roof	300lt-3x2.00m ²	1005	920	3315	-	2540	1835	281
	300lt-3x2.37m ²	1005	920	3975	-	2540	1835	299
	300lt-3x2.72m ²	1005	1220	4065	-	2930	1992	317

ELITK series, low height, low tilt

SYSTEMS WITH ONE COLLECTOR, SAME SUPPORT FOR FLAT OR INCLINED CONFIGURATION

flat roof configuration, 1 collector

flat roof configuration, 2 collectors

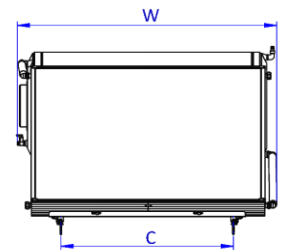
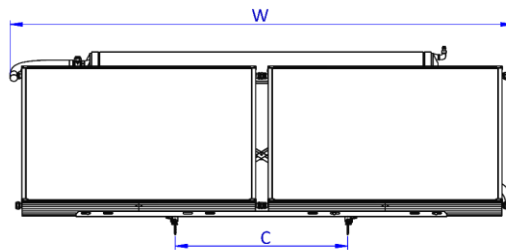
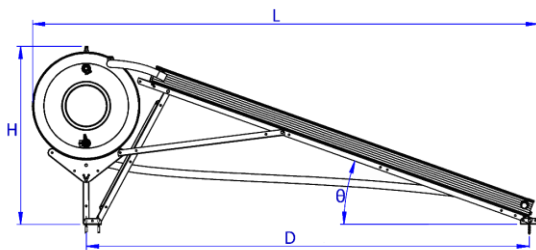

SYSTEM MAIN DIMENSIONS

Model	C [mm] flat	W [mm] flat	H [mm] flat	L [mm] flat	D [mm] flat	θ	Weight empty [kg]
120lt-1x2.00m ²	650	1150	950	2505	2165	22°	111
160lt-1x2.00m ²	840	1250	950	2505	2165	22°	120
160lt-1x2.37m ²	840	1310	950	2505	2165	22°	125
160lt-1x2.72 m ²	840	1385	950	2730	2395	20°	140
200lt-1x2.00m ²	930	1450	950	2505	2165	22°	143
200lt-1x2.37m ²	930	1450	950	2505	2165	22°	150
200lt-1x2.72 m ²	930	1480	950	2730	2395	20°	158
200lt-2x2.00 m ²	930	2180	950	2505	2165	22°	182
250lt-1x2.72m ²	930	1840	950	2730	2395	20°	183
250lt-2x2.00m ²	930	2180	950	2505	2165	22°	207
250lt-2x2.37m ²	930	2600	950	2505	2165	22°	219
300lt-2x2.00 m ²	930	2180	950	2505	2165	22°	220
300lt-2x2.37 m ²	930	2600	950	2505	2165	22°	232
300lt-2x2.72m ²	930	2700	950	2730	2395	20°	245



PAPAEMMANOUEL SA
SOLAR SYSTEMS INDUSTRY
Address: 1st Km. Inofyta-St. Thomas
GR-32011, Inofyta-Viotia, Greece
Tel.: +30 22620 31931
e-mail: exports@papaemmanouel.gr
Web : www.papaemmanouel.gr